



Paper Type: Original Article

## A Study on IoT-Enabled Smart Vehicles for Road Navigation and Ride Comfortability in Contemporary Vehicle Applications

Imoh Ime Ekanem<sup>1,\*</sup> , Aniekan Essienubong Ikpe<sup>1</sup> , Jephhtar Uviefowwe Ohwoekewwo<sup>1</sup> 

<sup>1</sup> Department of Mechanical Engineering, Akwa Ibom State Polytechnic, Ikot Osurua, Ikot Ekpene, Nigeria; imoh.ekanem@akwaibompoly.edu.ng; aniekan.ikpe@akwaibompoly.edu.ng; jephhtar.ohwoekewwo@eng.uniben.edu.

Citation:

Received: 20 April 2024

Revised: 16 June 2024

Accepted: 03 October 2024

Ime Ekanem, I., Essienubong Ikpe, A., & Uviefowwe Ohwoekewwo, J. (2024). A study on iot-enabled smart vehicles for road navigation and ride comfortability in contemporary vehicle applications. *Soft Computing Fusion with Applications*, 1 (1), 58-78.

### Abstract

Traditional navigation systems in vehicles often lack real-time data and personalized recommendations, leading to inefficient route planning and subpar ride comfortability. Drivers may encounter traffic congestion, road closures, and other obstacles that can disrupt their journey and increase stress levels. Additionally, the lack of connectivity and automation in vehicles can limit the ability to optimize routes, monitor vehicle performance, and enhance ride comfortability. With the advent of IoT technology, smart vehicles have the potential to address these issues by providing accurate and up-to-date information to drivers and passengers. The limitations highlight the conventional innovative solutions that can improve the overall driving experience and make transportation more convenient and enjoyable for users. The study adopted an argumentative approach combined with theoretical insights that involved a thorough analysis of existing literature and a case study on the trends, benefits, challenges, and potential impacts of IoT technology on the driving experience in modern vehicles. The research methodology included reviewing relevant studies on IoT technology, smart vehicles, transportation systems, and IoT-enabled vehicle features using online databases. The findings suggest that IoT-enabled smart vehicles have the potential to revolutionize road navigation and ride comfortability. By leveraging real-time data and connectivity features, these vehicles can provide drivers with accurate traffic updates, optimize routes based on current conditions, and even predict maintenance needs to prevent breakdowns. Regarding ride comfortability, IoT technology enables personalized settings for temperature, music, and seating preferences, as well as automated driving features that reduce driver fatigue and improve safety. The outcomes of this study highlight the transformative power of IoT-enabled smart vehicles in enhancing the driving experience and shaping the future of transportation. However, data privacy and security concerns must be addressed to fully realize IoT technology's benefits in smart vehicles.

**Keywords:** IoT technology, Smart vehicles, Road navigation, Ride comfortability, Transportation.

## 1 | Introduction

The Internet of Things (IoT) has revolutionized how we interact with technology, connecting devices and systems to enhance efficiency and convenience [1]. One of the most promising applications of IoT is in the automotive industry, where IoT-enabled vehicles are transforming how we drive, communicate, and interact

 Corresponding Author: imoh.ekanem@akwaibompoly.edu.ng



Licensee System Analytics. This article is an open access article distributed under the terms and conditions of the Creative Commons Attribution (CC BY) license (<http://creativecommons.org/licenses/by/4.0>).

with our surroundings. IoT-enabled vehicles, also known as connected cars, are equipped with internet connectivity, actuators, and a range of sensors and devices that enable them to communicate with each other, with infrastructure, cloud, and other devices [2]. For example, smart vehicles can automatically adjust their speed and direction based on traffic conditions, weather, and road hazards. They can also communicate with each other to coordinate movements and avoid collisions. These vehicles can collect and transmit data in real-time, allowing for improved road safety, efficiency, and convenience. By leveraging IoT technology, connected cars can communicate with each other to avoid accidents, optimize traffic flow, and provide valuable information to drivers and passengers [3].

IoT-enabled smart vehicles have become increasingly popular due to their ability to enhance ride comfort and driver satisfaction. IoT-enabled vehicles are equipped with a wide range of sensors and devices that enable them to collect and transmit data on various aspects of their operation and connectivity features that allow them to communicate with other vehicles, infrastructure, and the cloud. These sensors can monitor the vehicle's performance, location, speed, and surrounding environment, providing valuable insights to drivers, manufacturers, and service providers [4]. Connected cars can also communicate with each other through Vehicle-to-Vehicle (V2V) communication, enabling them to share information on road conditions, traffic patterns, and potential hazards in real-time. These vehicles can collect and analyze data in real time, enabling them to make informed decisions to improve the driving experience. For example, IoT-enabled smart vehicles can adjust the suspension system based on road conditions, monitor driver behavior to provide personalized recommendations, and even communicate with traffic lights to optimize traffic flow [5]. One of the key benefits of IoT-enabled smart vehicles is their ability to enhance ride comfort. By continuously monitoring road conditions, traffic patterns, and driver behavior, these vehicles can adjust various parameters such as suspension stiffness, seat position, and cabin temperature to provide a smooth and comfortable ride.

IoT-enabled smart vehicles can also detect and mitigate potential safety hazards, such as sudden braking or lane departure, to ensure a safe and comfortable driving experience. Furthermore, IoT-enabled smart vehicles can also improve driver satisfaction by providing personalized recommendations and assistance [6]. For example, these vehicles can suggest alternate routes to avoid traffic congestion, recommend nearby restaurants or gas stations, and adjust the music playlist based on the driver's mood. By leveraging data analytics and Artificial Intelligence (AI), IoT-enabled smart vehicles can create a personalized and enjoyable driving experience for the driver. The integration of IoT technology in vehicles has the potential to revolutionize the automotive industry, offering a wide range of benefits to drivers, manufacturers, and society as a whole. Connected cars can improve road safety by alerting drivers to potential hazards and assisting them in avoiding accidents. They can also optimize traffic flow by coordinating with other vehicles and infrastructure to reduce congestion and improve efficiency [7].

IoT-enabled vehicles can provide valuable data to manufacturers on vehicle performance, maintenance needs, and customer preferences, enabling them to develop more advanced and personalized products and services. One of the key advantages of IoT-enabled smart vehicles is their ability to provide drivers with real-time navigation assistance. By leveraging sensors, GPS technology, and connectivity to the Internet, these vehicles can offer accurate and up-to-date information on traffic conditions, road closures, and alternative routes. This helps drivers reach their destinations more efficiently and reduces the likelihood of accidents and traffic congestion. Furthermore, IoT technology can enhance ride comfortability by enabling vehicles to adjust various settings based on the preferences of the driver and passengers. For example, smart vehicles can adjust the temperature, lighting, and seating position automatically to create a more personalized and comfortable driving experience.

Additionally, IoT-enabled vehicles can monitor the health and well-being of passengers, providing alerts and assistance in emergencies [8]. Despite the numerous benefits of IoT-enabled smart vehicles, several challenges must be addressed. One of the main concerns is the potential security risks associated with connecting vehicles to the Internet. Hackers could potentially gain access to sensitive information or even take control of the vehicle, posing a serious threat to the safety of drivers and passengers [9]. Therefore, robust

cybersecurity measures must be implemented to protect IoT-enabled vehicles from malicious attacks. IoT-enabled smart vehicles have the potential to revolutionize the automotive industry by enhancing ride comfort and driver satisfaction. By leveraging sensors, connectivity, and data analytics, these vehicles can provide a smooth and comfortable driving experience while offering personalized recommendations and assistance to the driver. As technology advances, IoT-enabled smart vehicles will play an increasingly important role in shaping the future of transportation [10]. This study aims to provide a comprehensive survey of IoT-enabled vehicles, highlighting their potential impact on road navigation and ride comfortability in the automotive industry

## 2 | History of IoT-Enabled Smart Vehicles

Contemporary vehicles have come a long way since the invention of the first automobile in the late 19th century. Initially, vehicles were machines with basic mechanical components such as engines, transmissions, and brakes [11]. Over time, technological advancements introduced features such as power steering, air conditioning, and cruise control, making driving more comfortable and convenient for users. The integration of electronic components into vehicles in the 1980s marked a significant milestone in the evolution of contemporary vehicle applications [12]. This led to the development of features such as electronic fuel injection, anti-lock braking systems, and airbags, improving safety and performance. However, these advancements were limited in their ability to communicate with other vehicles or external systems. One of the earliest examples of IoT technology in vehicles can be traced back to the 1990s, with the introduction of OnStar by General Motors [13]. OnStar was a subscription-based service that provided drivers with features such as automatic crash response, roadside assistance, and vehicle diagnostics. This marked the beginning of IoT integration in vehicles, paving the way for future innovations in smart vehicle applications. The historical evolution of IoT-enabled smart vehicles can be traced back to the early 2000s when automakers began experimenting with connected car technologies. Introducing features such as GPS navigation, telematics, and remote vehicle monitoring laid the foundation for developing IoT-enabled smart vehicles [14].

Also, sensor technology and connectivity advancements in the early 2000s led to the development of more sophisticated IoT-enabled vehicle features. Companies like Ford and BMW began incorporating remote vehicle monitoring, GPS navigation, and voice-activated controls in their vehicles. These advancements not only improved the driving experience for consumers but also laid the foundation for developing autonomous vehicles. The emergence of autonomous vehicles in the 2010s further propelled the evolution of IoT-enabled smart vehicles. Companies like Tesla, Google, and Uber began testing and deploying self-driving vehicles with advanced sensors, cameras, and connectivity [15].

These vehicles could collect and analyze vast amounts of data in real-time, enabling them to navigate roads, detect obstacles, and make decisions autonomously. The emergence of IoT technology in the early 21st century revolutionized the automotive industry, leading to the development of smart vehicles connected to the Internet and communicating with other vehicles, infrastructure, and devices. IoT-enabled smart vehicles are equipped with sensors, actuators, and communication modules that enable them to collect and exchange data in real time, providing drivers with valuable information about their surroundings and enabling autonomous driving capabilities [16].

Today, IoT-enabled smart vehicles have become more prevalent in the automotive industry, with features such as adaptive cruise control, lane-keeping assist, and automatic parking becoming standard in many new vehicles. Integrating IoT technology has not only improved the safety and efficiency of vehicles but has also opened up new possibilities for connected services and applications. In recent years, advancements in IoT technology have enabled the integration of AI, machine learning, and cloud computing into smart vehicles, enabling them to analyze and process large amounts of data in real time [17]. This has led to the development of autonomous driving systems, smart parking solutions, and V2V communication protocols, making driving safer and more efficient.

### 3 | Advancements in IoT-Enabled Smart Vehicles

The automotive industry has recently witnessed significant advancements in integrating IoT technology into smart vehicles. IoT-enabled smart vehicles are revolutionizing how we perceive and interact with contemporary vehicle applications. The key milestones in the development of IoT-enabled smart vehicles are as follows:

- I. The integration of sensors and connectivity features: these sensors collect data on various aspects of the vehicle's performance, such as engine temperature, tire pressure, and fuel consumption. This data is transmitted to a central server through a wireless connection, allowing for real-time monitoring and analysis. This level of connectivity enables predictive maintenance, reducing the risk of breakdowns and improving overall vehicle reliability [18].
- II. The introduction of connected car technology: this technology allowed vehicles to communicate with each other and with infrastructure, such as traffic lights and road signs, to improve safety and efficiency on the road. Another milestone was the integration of IoT sensors and devices into vehicles, enabling them to monitor and adjust various systems, such as engine performance and tire pressure, in real-time [19].
- III. The integration of AI and machine learning algorithms: these algorithms analyze the data collected by sensors to identify patterns and trends, allowing for more accurate predictions and recommendations. For example, AI-powered systems can detect signs of engine failure before they occur, enabling proactive maintenance and reducing repair costs [20].
- IV. Furthermore, IoT-enabled smart vehicles are equipped with Advanced Driver Assistance Systems (ADAS) that enhance safety and convenience. These systems use sensors and cameras to monitor the vehicle's surroundings and provide real-time feedback to the driver. For example, lane departure warning systems alert the driver if they drift out of their lane, while adaptive cruise control adjusts the vehicle's speed to maintain a safe distance from other vehicles [21].
- V. In recent years, major automotive manufacturers have invested heavily in IoT technology to develop autonomous vehicles that can operate without human intervention. These vehicles rely on sensors, cameras, and other IoT devices to navigate roads, detect obstacles, and communicate with other vehicles. The development of autonomous vehicles represents a significant advancement in-vehicle applications and can potentially revolutionize how we travel [22].
- VI. IoT-enabled smart vehicles represent a significant advancement in contemporary vehicle applications. Integrating sensors, connectivity features, AI, and ADAS systems has transformed how we interact with vehicles, making them safer, more reliable, and more efficient. As technology continues to evolve, we can expect further innovations in the field of smart vehicles, ultimately leading to a more connected and intelligent transportation system.

### 4 | Commonly Used Software in IoT-Enabled Smart Vehicles

IoT-enabled smart vehicles rely on a wide range of software applications to enable seamless communication between various components and systems. The list of commonly used software in IoT-enabled smart vehicles is presented in *Table 1*.

**Table 1. Commonly used software in IoT-enabled smart vehicles.**

S/N.	Features	Software
1	Operating systems	Android auto: a mobile app developed by Google that allows users to mirror their android device's screen onto a car's infotainment display [23]. Apple CarPlay: similar to android auto, apple CarPlay enables iPhone users to access their phone's features through a car's infotainment system [24]. QNX: a real-time operating system commonly used in automotive infotainment systems for its reliability and security features [25].
2	Connectivity software	Bluetooth: enables wireless communication between a vehicle and external devices such as smartphones, tablets, and wearables [26]. Wi-Fi: provides high-speed internet connectivity for streaming music, accessing navigation services, and downloading software updates [27]. Cellular networks: allow vehicles to connect to the internet for real-time traffic updates, remote diagnostics, and over-the-air software updates.
3	Telematics software	OnStar: General Motors' telematics system that provides emergency assistance, vehicle diagnostics, and remote vehicle control features [28]. BMW connected drive: BMW's telematics platform offering services such as concierge assistance, remote door lock/unlock, and stolen vehicle tracking. Ford pass: ford's mobile app allows users to start their vehicle remotely, locate it in a parking lot, and schedule maintenance appointments [29].
4	ADAS software	Adaptive cruise control: automatically adjusts a vehicle's speed to maintain a safe following distance from the vehicle ahead [30]. Lane departure warning: alerts drivers when they unintentionally drift out of their lane without using a turn signal. Automatic emergency braking: applies the brakes automatically to prevent or mitigate a collision with another vehicle or pedestrian [31].
5	Infotainment software	Spotify: a popular music streaming service that allows users to listen to their favorite songs and playlists while driving. Google Maps: provides real-time navigation, traffic updates, and points of interest information to help drivers reach their destinations efficiently [32]. Amazon alexa: enables voice-controlled access to music, news, weather, and smart home devices from within the vehicle.

IoT-enabled smart vehicles rely on diverse software applications to deliver a seamless and connected driving experience. From operating systems and connectivity software to telematics and ADAS systems, each component plays a crucial role in enhancing modern vehicles' safety, convenience, and entertainment features.

## 5 | Hardware Components in IoT-Enabled Smart Vehicles

Smart vehicles are equipped with a wide range of hardware components. These hardware components are crucial in enabling various functionalities and features in IoT-enabled smart vehicles. The common hardware used in IoT-enabled smart vehicles is enlisted as follows:

- I. **Sensors:** sensors are one of the key hardware components in IoT-enabled smart vehicles. These sensors include various types, such as proximity sensors, temperature sensors, pressure sensors, and motion sensors. These sensors are used to collect data from the vehicle's surroundings and provide input to the vehicle's control systems [33].
- II. **GPS Module:** GPS modules are essential hardware components in IoT-enabled smart vehicles as they enable the vehicle to determine its location accurately. This information is crucial for navigation systems, tracking, and other location-based services [34].
- III. **Cameras:** cameras are another important hardware component in IoT-enabled smart vehicles. These cameras are used for various purposes, such as capturing images and videos for security and surveillance, assisting in parking and maneuvering, and enabling ADAS [35].



- IV. Communication modules: communication modules such as Wi-Fi, Bluetooth, and cellular are essential hardware components in IoT-enabled smart vehicles. These modules enable the vehicle to communicate with other vehicles, as well as infrastructure and cloud-based services for data exchange and connectivity.
- V. Control units: control units are hardware components that manage and control various systems in the vehicle, such as the engine, transmission, brakes, and steering. These control units are equipped with sensors and actuators to monitor and regulate the vehicle's performance.
- VI. Display units: display units such as touchscreens, LCD screens, and heads-up displays are hardware components that provide visual feedback and information to the driver and passengers. These displays are used for navigation, entertainment, and vehicle status monitoring [36].
- VII. Actuators: actuators are hardware components that convert electrical signals into mechanical motion. These actuators are used in various systems in IoT-enabled smart vehicles, such as the engine, brakes, and steering, to control and regulate their operations [37].
- VIII. IoT-enabled smart vehicles are equipped with a wide range of hardware components that enable them to provide advanced functionalities and features. The hardware components listed above play a crucial role in the operation and performance of IoT-enabled smart vehicles.

## 6 | Key Features in IoT-Enabled Vehicles

The technology behind IoT-enabled vehicles has opened up a world of possibilities for improving vehicle safety, efficiency, and convenience. The key features of IoT-enabled vehicles are as follows:

- I. One of the key features of IoT-enabled vehicles is real-time monitoring and diagnostics. Through sensors and connectivity, vehicles can constantly monitor their performance and health, alerting drivers to any issues that may arise. This can help prevent breakdowns and accidents and save time and money on maintenance [38].
- II. Another important feature is predictive maintenance. By analyzing sensor data and historical performance, IoT-enabled vehicles can predict when parts will likely fail and alert drivers to schedule maintenance before a breakdown occurs. This can help prevent costly repairs and keep vehicles running smoothly.
- III. IoT-enabled vehicles also offer enhanced security features. With connectivity to the Internet, vehicles can be tracked in real-time, making it easier to recover stolen vehicles. Additionally, features such as remote locking and unlocking, geofencing, and immobilization can help prevent theft and unauthorized use of vehicles [39].
- IV. In terms of convenience, IoT-enabled vehicles offer a range of features that make driving easier and more enjoyable. For example, vehicles can be connected to smart home devices, allowing drivers to control their home appliances from their cars. In-car entertainment systems can also be connected to the Internet, providing access to streaming services, navigation, and other apps.
- V. IoT-enabled vehicles also offer improved communication and connectivity. Vehicles can communicate with each other to share information about road conditions, traffic, and accidents, helping to improve safety and efficiency on the roads. Additionally, vehicles can connect to smart city infrastructure, such as traffic lights and parking meters, to optimize traffic flow and availability [40].
- VI. IoT-enabled smart vehicles offer a wide range of features that can improve safety, efficiency, and convenience for drivers. From real-time monitoring and diagnostics to predictive maintenance, enhanced security, and improved communication, IoT-enabled vehicles are transforming the way we drive.

## 7 | Maintenance Alerts in IoT-Enabled Smart Vehicles

Maintenance alerts in IoT-enabled smart vehicles are crucial for ensuring these advanced vehicles' optimal performance and safety. These alerts are designed to notify drivers and service technicians about potential issues with the vehicle that require attention. Maintenance alerts in IoT-enabled smart vehicles can be defined as notifications generated by the vehicle's onboard sensors and systems to alert the driver or service technician about potential maintenance issues [41]. These alerts are typically sent to the driver's smartphone or displayed

on the vehicle's dashboard, providing real-time information about the vehicle's health and performance. The operation principles of maintenance alerts in IoT-enabled smart vehicles are based on continuously monitoring the vehicle's systems and components using sensors and connected devices. These sensors collect data on parameters such as engine temperature, oil level, tire pressure, and battery health [42]. This data is then analyzed by the vehicle's onboard computer system, which uses algorithms to detect any abnormalities or potential issues. When a problem is detected, a maintenance alert is generated and sent to the driver or service technician. The functions of maintenance alerts in IoT-enabled smart vehicles are multifaceted. Firstly, these alerts help drivers to proactively address maintenance issues before they escalate into more serious problems.

By receiving timely notifications about low tire pressure or engine malfunctions, drivers can take the necessary actions to prevent breakdowns and accidents. Secondly, maintenance alerts also help service technicians to diagnose and repair issues more efficiently. By providing detailed information about the nature and location of the problem, these alerts enable technicians to quickly identify the root cause and take appropriate measures to fix it.

## 8 | Telematics Systems in IoT-Enabled Smart Vehicles

Telematics systems in IoT-enabled smart vehicles are revolutionizing how we interact with our cars and the world around us. These systems combine telecommunications and informatics to provide a wide range of functions and services that enhance the driving experience and improve safety on the road. Telematics systems are integrated into telecommunications and informatics technologies to provide real-time data and information about a vehicle's performance, location and condition [43]. These systems use sensors, GPS technology, and wireless communication to collect and transmit data to a central server or cloud-based platform, which can be analyzed and used to improve vehicle performance, monitor driver behavior, and provide valuable insights for fleet management and insurance purposes. The operation principles of telematics systems in smart vehicles are based on collecting, transmitting, and analyzing data from various sensors and devices installed in the vehicle. These sensors can monitor multiple parameters, such as engine performance, fuel consumption, tire pressure, and driver behavior, and transmit this data wirelessly to a central server or cloud-based platform [44].

The data is then analyzed using advanced algorithms to provide real-time insights and alerts to drivers, fleet managers, and other stakeholders. The functions of telematics systems in smart vehicles are diverse. They can include vehicle tracking and location services, remote diagnostics and maintenance alerts, driver behavior monitoring and coaching, and emergency and roadside assistance services. These functions can help improve fuel efficiency, reduce maintenance costs, enhance driver safety, and provide valuable data for insurance companies and fleet managers to optimize their operations.

## 9 | ADAS in IoT-Enabled Smart Vehicles

ADAS are a crucial component of IoT-enabled smart vehicles, providing drivers with enhanced safety and convenience features. These systems utilize a combination of sensors, cameras, and AI to assist drivers in various aspects of driving, such as lane-keeping, collision avoidance, and parking assistance. ADAS can be defined as a set of technologies that assist drivers in the driving process, with the ultimate goal of improving safety and reducing accidents on the road [21]. These systems are designed to provide real-time feedback and alerts to drivers, helping them make better decisions and avoid potential hazards. ADAS can include adaptive cruise control, lane departure warning, automatic emergency braking, and blind spot detection. The operation principles of ADAS are based on integrating various sensors and cameras that continuously monitor the vehicle's surroundings.

These sensors collect data on the vehicle's speed, position, and proximity to other vehicles and obstacles, while the cameras provide visual information on the road conditions. This data is then processed by the system's onboard computer, which uses AI algorithms to analyze the information and provide feedback to

the driver [45]. The functions of ADAS in IoT-enabled smart vehicles are diverse and can greatly enhance the driving experience. One of the key functions of ADAS is collision avoidance, which uses sensors to detect potential collisions and automatically apply the brakes or steer the vehicle away from danger. Another important function is lane-keeping assistance, which helps drivers stay in their lane by providing alerts and gentle steering corrections. ADAS can also assist with parking by providing visual and auditory cues to help drivers navigate tight spaces [46]. ADAS with IoT-enabled features in smart vehicles is presented in *Fig 1*.

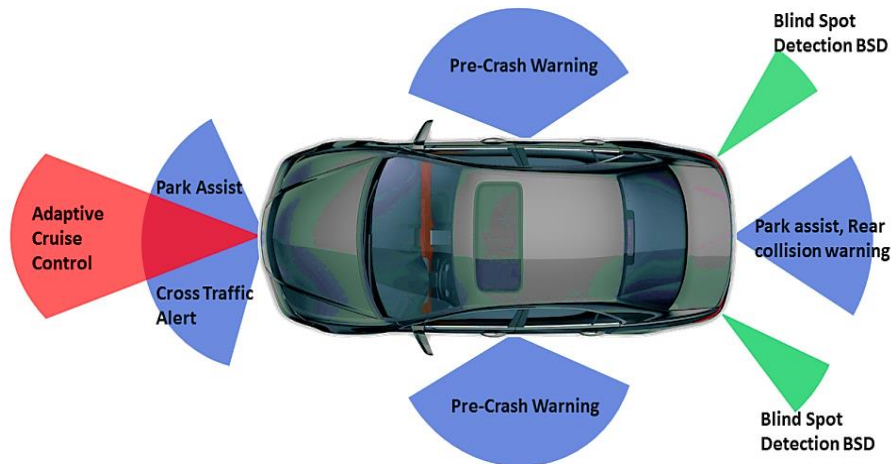

Fig. 1. ADAS with IoT-enabled features in smart vehicles [47].

## 10 | Connected Infotainment Systems in IoT-Enabled Smart Vehicles

Connected infotainment systems in IoT-enabled smart vehicles are becoming increasingly popular in the automotive industry. These systems provide a wide range of features and functions that enhance the driver's and passengers' driving experience [48]. Connected infotainment systems can be defined as integrated multimedia systems that provide entertainment, information, and communication services to vehicle occupants. These systems typically include features such as navigation, music streaming, hands-free calling, and internet connectivity. They are designed to enhance the overall driving experience by providing access to a wide range of services and content. The operation principles of connected infotainment systems are based on integrating various technologies such as GPS, Bluetooth, Wi-Fi, and cellular connectivity. These technologies allow the system to communicate with external sources such as smartphones, cloud services, and other vehicles [49]. By leveraging these technologies, connected infotainment systems can provide real-time information, entertainment, and communication services to vehicle occupants.

The functions of connected infotainment systems in IoT-enabled smart vehicles are diverse and multifaceted. One of the key functions of these systems is navigation, which allows drivers to access real-time traffic information, route guidance, and points of interest. This helps drivers to navigate efficiently and safely to their destination. Another important function is music streaming, which allows passengers to listen to their favorite music or podcasts while on the road. Additionally, connected infotainment systems can provide hands-free calling and messaging services, allowing drivers to stay connected while keeping their hands on the wheel [50].

## 11 | Remote Diagnostics in IoT-Enabled Smart Vehicles

Remote diagnostics in IoT-enabled smart vehicles refer to the ability to monitor and diagnose vehicle issues from a remote location using IoT technology. This technology allows for real-time monitoring of vehicle performance and health, enabling timely maintenance and repairs to be conducted before major issues arise [51]. The operation principles of remote diagnostics in smart vehicles involve installing sensors and connectivity devices to collect data on various parameters such as engine performance, fuel efficiency, and tire pressure. This data is then transmitted to a central server or cloud-based platform, which is analyzed using



algorithms to detect any anomalies or potential issues. Alerts are then sent to the vehicle owner or service provider, enabling them to take appropriate action. The functions of remote diagnostics in smart vehicles include proactive maintenance, predictive analysis, and remote troubleshooting (Mnyakin, 2023). Proactive maintenance involves monitoring vehicle performance and scheduling maintenance tasks based on actual usage rather than fixed intervals. Predictive analysis uses historical data and machine learning algorithms to predict potential failures before they occur, allowing for preventive measures to be taken. Remote troubleshooting enables service technicians to diagnose and fix issues remotely, reducing the need for physical inspections and minimizing downtime [52].

Overall, remote diagnostics in IoT-enabled smart vehicles offer numerous benefits, such as improved vehicle reliability, reduced maintenance costs, and enhanced safety. By leveraging IoT technology, vehicle owners and service providers can ensure optimal performance and longevity of their vehicles.

## 12 | Vehicle-to-Vehicle Communication IoT-Enabled Smart Vehicles

V2V communication systems enable vehicles to exchange data with each other using wireless communication technologies. These systems use Dedicated Short-Range Communication (DSRC) or cellular networks to transmit and receive data between vehicles. V2V communication systems can provide a wide range of benefits, including improved road safety, reduced traffic congestion, and enhanced driver convenience [53]. V2V communication systems are defined as a technology that allows vehicles to communicate with each other in real-time, sharing information such as speed, location, and road conditions. These systems use wireless communication technologies to enable vehicles to exchange data and coordinate their movements on the road. V2V communication systems are a key component of IoT-enabled smart vehicles, allowing them to communicate with other vehicles, infrastructure, and cloud-based services [54]. The operation principles of V2V communication systems are based on data exchange between vehicles using wireless communication technologies. These systems use DSRC or cellular networks to transmit and receive data between vehicles, enabling them to share information such as speed, location, and road conditions. V2V communication systems use advanced algorithms and protocols to ensure reliable and secure communication between vehicles, allowing them to coordinate their movements and avoid collisions on the road [55]. The features of IoT communication systems in smart vehicles are shown in Fig. 2.

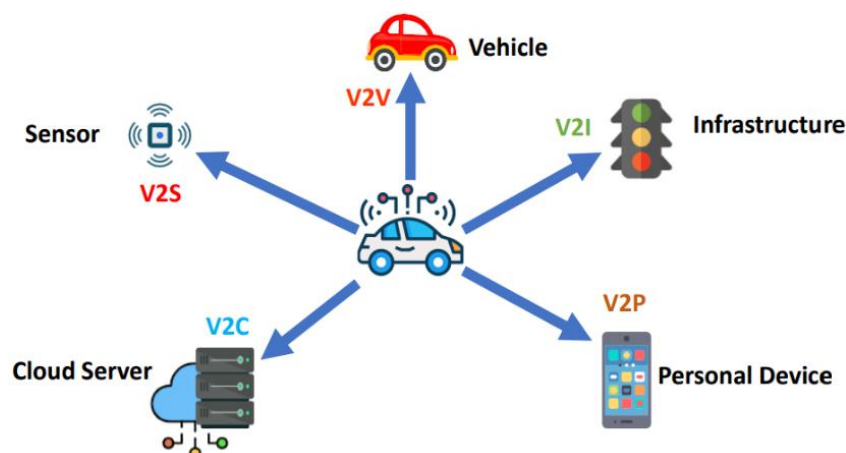

Fig. 2. IoT communication systems features in smart vehicles [56].

The functions of V2V communication systems in IoT-enabled smart vehicles are diverse and include:

- I. Collision avoidance: V2V communication systems can alert drivers to potential collisions with other vehicles, pedestrians, or obstacles on the road, helping to prevent accidents and improve road safety [57].
- II. Traffic management: V2V communication systems can provide drivers with real-time traffic information, helping them avoid congestion and choose the most efficient routes [58].

- III. Emergency services: V2V communication systems can automatically alert emergency services in the event of an accident, providing them with important information such as the location and severity of the crash [58].
- IV. Vehicle-to-infrastructure communication: V2V communication systems can also communicate with roadside infrastructure, such as traffic lights and road signs, to improve traffic flow and enhance driver safety [59].

V2V communication systems provide a wide range of benefits, including improved road safety, reduced traffic congestion, and enhanced driver convenience. By understanding the principles of V2V communication systems, one can see that their importance in developing smart and connected vehicles can be highly appreciated.

### 13 | DSRC in IoT-Enabled Smart Vehicles

DSRC is a wireless communication technology that enables vehicles to communicate with each other and with roadside infrastructure to improve road safety and efficiency [60]. In the context of IoT-enabled smart vehicles, DSRC plays a crucial role in enabling vehicles to exchange information in real time, allowing for better decision-making and coordination on the road. DSRC operates on the 5.9 GHz frequency band and uses a combination of wireless communication protocols to facilitate communication between vehicles and infrastructure. The technology allows vehicles to broadcast their speed, position, and other relevant information to nearby vehicles, enabling them to anticipate potential hazards and take appropriate action to avoid accidents [61]. In addition, DSRC can also be used to communicate with roadside infrastructure, such as traffic lights and road signs, to provide drivers with real-time information about road conditions and traffic patterns [62]. The operation principles of DSRC are based on the concept of V2V and Vehicle-to-Infrastructure (V2I) communication. V2V communication allows vehicles to exchange information, such as speed, position, and heading, to detect potential collisions and coordinate their movements. V2I communication, on the other hand, enables vehicles to communicate with roadside infrastructure to receive information about traffic conditions, road closures, and other relevant data.

The functions of DSRC in IoT-enabled smart vehicles are manifold. Firstly, DSRC enables vehicles to communicate with each other and infrastructure in real-time, allowing for improved situational awareness and decision-making on the road. This can help reduce accidents and improve overall road safety [63]. Secondly, DSRC can be used to enable ADAS in smart vehicles, such as collision avoidance systems and adaptive cruise control, which rely on real-time communication between vehicles to operate effectively. Finally, DSRC can also be used to enable new applications and services in smart vehicles, such as traffic management systems and vehicle-to-grid communication, which can help improve transportation systems' efficiency and sustainability [64]. *Fig. 3* illustrates the principles of DSRC.

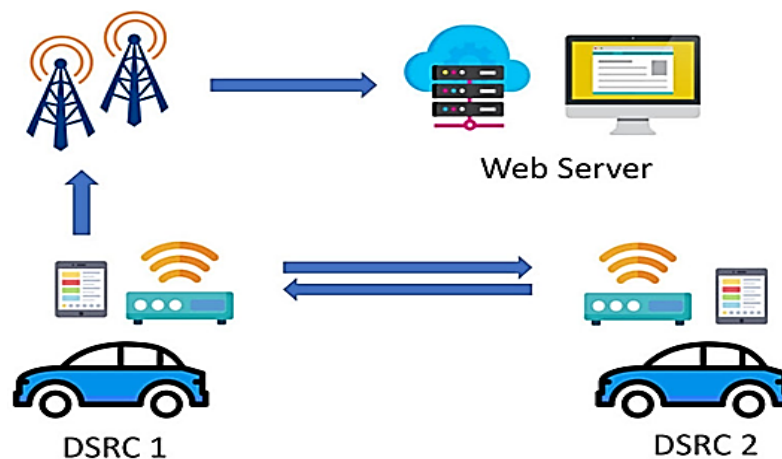
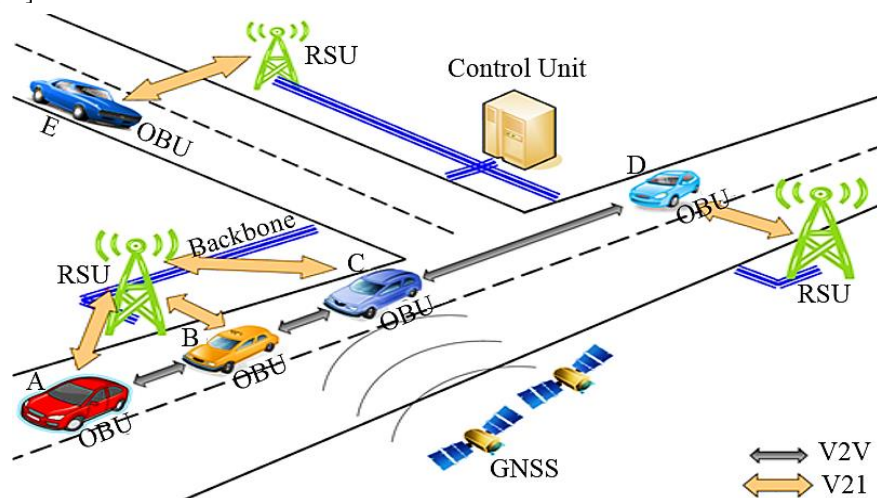

Fig. 3. DSRC [65].

## 14 | V2I Communication Systems in IoT-Enabled Smart Vehicles

V2I communication is a key component of the IoT-enabled smart vehicles. These systems enable vehicles to exchange information with infrastructure in real time. This information can include traffic conditions, road hazards, and other relevant data that can help drivers make informed decisions while on the road [66]. V2I communication systems can help reduce traffic congestion, improve road safety, and enhance overall transportation efficiency by connecting vehicles to infrastructure. V2I communication systems are a type of communication technology that allows vehicles to communicate with infrastructure such as traffic lights, road signs, and other vehicles. These systems use wireless technologies such as Wi-Fi, cellular networks, and DSRC to exchange real-time data between vehicles and infrastructure. The operation of V2I communication systems is based on the principles of wireless communication and data exchange [67]. Vehicles equipped with V2I communication technology can send and receive data to and from infrastructure using wireless communication protocols. This data can include information about traffic conditions, road hazards, and other relevant information that can help improve driving safety and efficiency. The main functions of V2I communication systems in IoT-enabled smart vehicles include:

- I. Traffic management: As shown in *Fig. 4*, V2I communication systems can manage traffic flow by providing real-time information about traffic conditions, road closures, and other relevant data to drivers [68].



**Fig. 4. Traffic management V2I communication [69].**

- II. Road safety: V2I communication systems can help improve road safety by alerting drivers to potential hazards such as accidents, road construction, and adverse weather conditions [70].
- III. Vehicle efficiency: V2I communication systems can help improve vehicle efficiency by providing information about optimal routes, traffic patterns, and other data to help drivers save time and fuel [71].

V2I communication systems can help improve traffic management, road safety, and overall driving efficiency by leveraging wireless communication technologies. As the automotive industry continues to embrace IoT technologies, V2I communication systems will play an increasingly important role in shaping the future of transportation.

## 15 | Sensors in IoT-Enabled Smart Vehicles

IoT-enabled smart vehicles are equipped with a wide range of sensors that collect and transmit data to improve safety, efficiency, and overall driving experience. Sensors in IoT-enabled smart vehicles are devices that detect changes in the vehicle's environment and convert them into electrical signals. These sensors are integrated into various vehicle components, such as the engine, brakes, steering system, and even the driver's seat. They can measure a wide range of parameters, including temperature, pressure, speed, proximity, and more [72]. The operation principles of sensors in IoT-enabled smart vehicles vary depending on their type

and function. However, most sensors work on the principle of detecting a physical change in the environment and converting it into an electrical signal. For example, a temperature sensor detects temperature changes and sends a signal to the vehicle's onboard computer, which adjusts the climate control system accordingly. The functions of sensors in IoT-enabled smart vehicles are diverse and crucial for the overall performance and safety of the vehicle. Some of the key functions of sensors include:

- I. Collision detection: sensors such as radar and lidar are used to detect obstacles and other vehicles on the road, helping to prevent accidents [73]. *Fig. 5* shows the schematics of the collision detection circuit, while *Fig. 6* illustrates the principles of collision detection sensors.

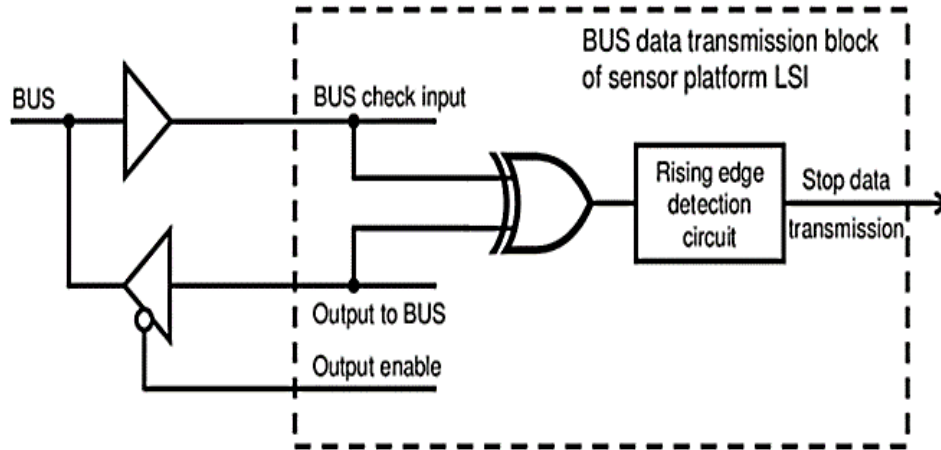

Fig. 5. Schematic of collision detection circuit [74].

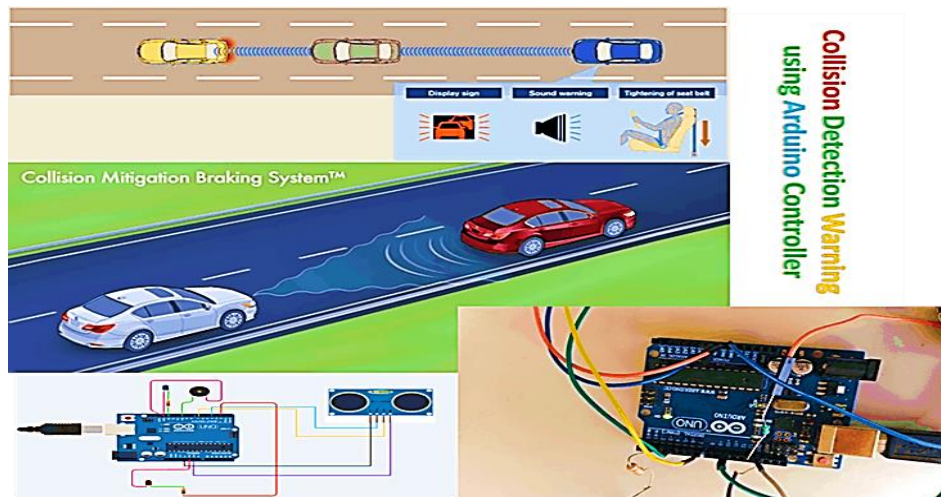

Fig. 6. Collision detection sensors [75].

- II. Adaptive cruise control: sensors monitor the distance between the vehicle and the vehicle in front, adjusting the speed accordingly to maintain a safe following distance [76].
- III. Lane departure warning: sensors detect when the vehicle drifts out of its lane and alert the driver to take corrective action.
- IV. Tire pressure monitoring: sensors monitor the air pressure in the tires and alert the driver if it falls below a safe level [77]. A pictorial view of tire pressure monitoring sensors is presented in *Fig. 7*.



Fig. 7. Tire pressure monitoring sensors [78].

- V. Parking assistance: sensors help drivers navigate tight parking spaces by detecting obstacles and providing guidance on parking.

Sensors play a crucial role in IoT-enabled smart vehicles by collecting and transmitting data to improve safety, efficiency, and overall driving experience. Understanding the description, definition, operation principles, and functions of sensors is essential for developing and implementing advanced automotive technologies.

## 16 | Interaction of IoT-Enabled Smart Vehicles with Road Navigation Systems

IoT-Enabled smart vehicles have revolutionized the way we navigate roads and highways. These vehicles are equipped with advanced technologies to interface with road navigation systems, providing drivers with real-time information and guidance to reach their destinations efficiently and safely [79]. One of the key features of IoT-enabled smart vehicles is their ability to connect to the Internet and access real-time traffic data. This data is collected from various sources, such as traffic cameras, sensors embedded in the road, and other vehicles. By analyzing this data, smart vehicles can determine the best route to avoid traffic congestion and accidents. This saves drivers time and reduces fuel consumption and emissions, contributing to a more sustainable transportation system. In addition to real-time traffic data, IoT-enabled smart vehicles can interface with GPS navigation systems to provide turn-by-turn directions to drivers [80]. These directions are based on the vehicle's location, destination, and traffic conditions, ensuring drivers stay on the optimal route.

Furthermore, smart vehicles can also communicate with each other to share information about road conditions, such as accidents, construction zones, and weather hazards. This collaborative approach to navigation helps drivers make informed decisions and stay safe on the road. Despite the numerous benefits of IoT-enabled smart vehicles, some challenges need to be addressed. One of the main concerns is the security and privacy of the data collected by these vehicles.

As smart vehicles become more connected, they are vulnerable to cyber-attacks and hacking attempts. Manufacturers and developers must implement robust security measures to protect the data and ensure the safety of drivers and passengers [81]. Another challenge is the interoperability of different IoT devices and road navigation systems. As smart vehicles interface with various road navigation systems, there is a need for standardization and compatibility to ensure seamless communication. This requires collaboration between manufacturers, government agencies, and other stakeholders to establish common protocols and standards for IoT-enabled smart vehicles. *Fig. 8* illustrates the interaction between IoT-enabled smart vehicles and road navigation systems.



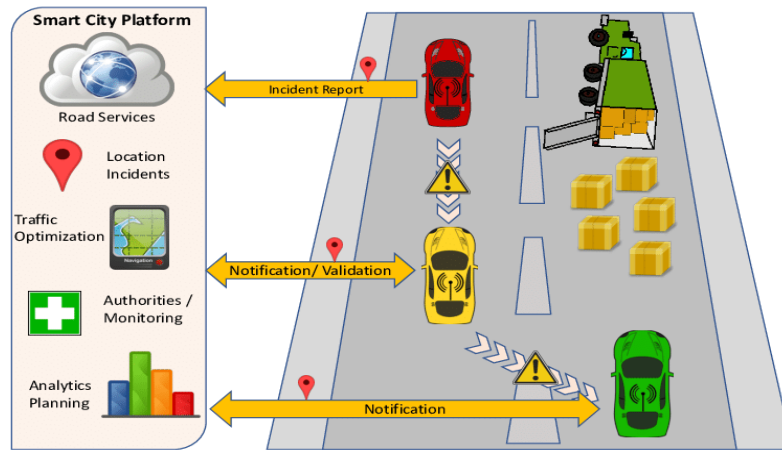

Fig. 8. Interaction of IoT-enabled smart vehicles with road navigation systems [82].

## 17 | Enhancement of Ride Comfortability in IoT-Enabled Smart Vehicles

One of the key benefits of IoT-enabled smart vehicles is the enhanced ride comfortability they provide to passengers. By leveraging IoT sensors and connectivity, these vehicles can collect and analyze real-time data to optimize various aspects of the ride experience, such as temperature control, seat adjustments, and entertainment options. IoT-enabled smart vehicles can enhance ride comfortability through the following ways:

- I. One of how IoT-enabled smart vehicles enhance ride comfortability is through personalized climate control. By monitoring the ambient temperature inside the vehicle and the preferences of individual passengers, IoT sensors can automatically adjust the climate settings to ensure optimal comfort for everyone on board. This improves the overall ride experience but also helps to reduce energy consumption by avoiding unnecessary heating or cooling [83].
- II. In addition to climate control, IoT-enabled smart vehicles also offer advanced seat adjustment features that cater to the unique needs of passengers. By collecting data on factors such as body posture, weight distribution, and seating preferences, these vehicles can automatically adjust the seats to provide optimal support and comfort. This not only helps to prevent discomfort and fatigue during long journeys but also reduces the risk of musculoskeletal injuries [84].
- III. Furthermore, IoT-enabled smart vehicles are equipped with entertainment systems seamlessly integrated with passengers' devices. By leveraging IoT connectivity, these vehicles can provide a wide range of entertainment options, such as streaming music, movies, and games, to keep passengers entertained and engaged throughout the journey. This not only enhances the overall ride experience but also helps to alleviate boredom and reduce stress [85].
- IV. IoT-enabled smart vehicles have significantly improved ride comfortability by leveraging real-time data and connectivity to optimize various aspects of the ride experience. From personalized climate control to advanced seat adjustments and entertainment options, these vehicles offer a level of comfort and convenience that was previously unimaginable. As IoT technology continues to evolve, more innovative features and enhancements that will further enhance the ride comfortability of smart vehicles are expected.

## 18 | Challenges Associated With Implementing IoT-Enabled Smart Vehicles

The implementation of IoT-enabled smart vehicles for road navigation and ride comfortability presents the following challenges that must be addressed in order to ensure successful deployment:

- I. Connectivity issues: one of the primary challenges in implementing IoT-enabled smart vehicles is ensuring seamless connectivity between the vehicle and the IoT network. This requires robust communication protocols and reliable network infrastructure for real-time data transmission [86].
- II. Data security: with the increase in data collected and transmitted by IoT-enabled smart vehicles, ensuring data security and privacy has become a critical challenge. Protecting sensitive information from cyber threats and unauthorized access is essential to maintaining the system's integrity [87].
- III. Integration with existing infrastructure: integrating IoT-enabled smart vehicles with existing road infrastructure and navigation systems poses a significant challenge. Compatibility and interoperability must be addressed to ensure seamless communication and coordination between vehicles and infrastructure [88].
- IV. Power consumption: IoT-enabled smart vehicles rely on various sensors and devices that consume significant amounts of power. Managing power consumption and ensuring efficient energy usage is essential to prolong the vehicle's battery life and maintain optimal performance [89].
- V. Regulatory compliance: deploying IoT-enabled smart vehicles for road navigation and ride comfortability is subject to various regulatory requirements and standards. Ensuring compliance with legal and regulatory frameworks is essential to avoid potential legal issues and liabilities.
- VI. User acceptance: despite the potential benefits of IoT-enabled smart vehicles, user acceptance and adoption remain a key challenge. Educating users about the capabilities and benefits of smart vehicles, addressing concerns about privacy and security, and providing user-friendly interfaces are essential to promote widespread adoption [90].

Implementing IoT-enabled smart vehicles for road navigation and ride comfortability presents a number of challenges that must be addressed to ensure successful deployment. Stakeholders can overcome these challenges by addressing connectivity issues, data security, integration with existing infrastructure, power consumption, regulatory compliance, and user acceptance.

## 19 | Conclusion

This study has shown that IoT-enabled smart vehicles offer advanced navigation systems that provide real-time traffic updates, route optimization, and predictive maintenance alerts. Additionally, these vehicles are equipped with sensors and actuators that enhance ride comfortability by adjusting suspension systems, seat positions, and climate control settings based on the preferences of the driver and passengers. Furthermore, the use of IoT technology in smart vehicles has the potential to improve road safety by enabling V2V communication and autonomous driving capabilities. This can reduce the likelihood of accidents and traffic congestion, ultimately leading to a more efficient and sustainable transportation system. The findings from this study highlight the significant benefits of integrating IoT technology in contemporary vehicle applications. The advanced features and capabilities of smart vehicles have the potential to enhance the overall driving experience, improve road safety, and contribute to a more sustainable transportation system. As IoT technology and smart vehicle development continue to advance, researchers, policymakers, and industry stakeholders need to collaborate and address challenges such as data privacy, cybersecurity, and infrastructure compatibility. By working together, the full potential of IoT-enabled smart vehicles can be unlocked, and a future where road navigation is seamless and ride comfortability is optimized for all passengers can be achieved. Based on the findings from this study, the following key recommendations are suggested to enhance the effectiveness and efficiency of smart vehicles in providing a seamless driving experience for users:

- I. Automotive manufacturers need to invest in further research and development to improve the integration of IoT technology in vehicles. This includes the development of advanced sensors, communication systems, and data analytics capabilities to enable real-time monitoring and control of vehicle functions. By leveraging IoT technology, smart vehicles can provide accurate navigation guidance, optimize fuel efficiency, and enhance overall ride comfort for passengers.

- II. Additionally, collaboration between automotive manufacturers, technology companies, and government agencies is essential to establish industry standards and regulations for deploying IoT-enabled smart vehicles. This will ensure interoperability and compatibility between different vehicle systems and address potential security and privacy concerns associated with collecting and sharing vehicle data.
- III. Furthermore, continuous testing and validation of IoT-enabled smart vehicles in real-world driving conditions are necessary to identify and address any potential issues or limitations. This will help improve the reliability and performance of smart vehicle systems and ensure users' safety and satisfaction.

IoT technology in smart vehicles has the potential to revolutionize the automotive industry and enhance the driving experience for users. By following these recommendations based on the findings from this study, automotive manufacturers can effectively leverage IoT technology to improve road navigation and ride comfortability in contemporary vehicle applications. Stakeholders must work together to drive innovation and ensure the successful implementation of IoT-enabled smart vehicles in the future.

## Author Contributions

Imoh Ime Ekanem conceptualized the research and contributed to writing – original draft. Aniekan Essienubong Ikpe handled data collection, analysis, and visualization. Jephtar Uviefowwe Ohwoekevwo provided the review, editing, and final approval of the manuscript.

## Funding

No specific funding was received for this research.

## Data Availability

Data used in this study are available from the corresponding author upon reasonable request.

## Conflicts of Interest

The authors declare no conflicts of interest regarding the publication of this article.

## References

- [1] Zeinab, K. A. M., & Elmustafa, S. A. A. (2017). Internet of things applications, challenges and related future technologies. *World scientific news*, 67(2), 126–148. <https://bibliotekanauki.pl/articles/1178659.pdf>
- [2] Rahim, M. A., Rahman, M. A., Rahman, M. M., Asyhari, A. T., Bhuiyan, M. Z. A., & Ramasamy, D. (2021). Evolution of IoT-enabled connectivity and applications in automotive industry: a review. *Vehicular communications*, 27, 100285. <https://www.sciencedirect.com/science/article/pii/S2214209620300565>
- [3] Phan, T. C., & Singh, P. (2023). A recent connected vehicle-IoT automotive application based on communication technology. *International journal of data informatics and intelligent computing*, 2(4), 40–51. <https://ijdiic.com/index.php/research/article/view/88>
- [4] Vermesan, O., Bahr, R., Falcitelli, M., Brevi, D., Bosi, I., Dekusar, A., ... Simeon, J. F. (2022). IoT technologies for connected and automated driving applications. In *Internet of things—the call of the edge* (pp. 255–306). River Publishers. <https://www.taylorfrancis.com/chapters/oa-edit/10.1201/9781003338611-6/>
- [5] Bellini, P., Nesi, P., & Pantaleo, G. (2022). IoT-enabled smart cities: a review of concepts, frameworks and key technologies. *Applied sciences*, 12(3), 1607.
- [6] Janeera, D. A., Gnanamalar, S. S. R., Ramya, K. C., & Kumar, A. G. A. (2021). Internet of things and artificial intelligence-enabled secure autonomous vehicles for smart cities. In *Automotive embedded systems: key technologies, innovations, and applications* (pp. 201–218). Cham: Springer International Publishing. DOI: 10.1007/978-3-030-59897-6\_11
- [7] Rahman, M. A., Ali, J., Kabir, M. N., & Azad, S. (2017). A performance investigation on IoT enabled intra-vehicular wireless sensor networks. *International journal of automotive and mechanical engineering*, 14(1), 3970–3984.

- [8] Ferrari, E. (2022). IoT-enabled environmental monitoring for autonomous vehicle safety. *Journal of ai-assisted scientific discovery*, 2(1), 86–107.
- [9] Guerrero-ibanez, J. A., Zeadally, S., & Contreras-Castillo, J. (2015). Integration challenges of intelligent transportation systems with connected vehicle, cloud computing, and internet of things technologies. *IEEE wireless communications*, 22(6), 122–128. DOI:10.1109/MWC.2015.7368833
- [10] Al-Turjman, F., & Lemayian, J. P. (2020). Intelligence, security, and vehicular sensor networks in internet of things (IoT)-enabled smart-cities: an overview. *Computers & electrical engineering*, 87, 106776. <https://www.sciencedirect.com/science/article/pii/S0045790620306315>
- [11] Wakefield, E. H. (1993). *History of the electric automobile: battery-only powered cars*. Society of Automotive engineers.
- [12] Sperling, D. (2018). *Three revolutions: Steering automated, shared, and electric vehicles to a better future*. Island Press.
- [13] Andersson, P., & Mattsson, L.-G. (2015). Service innovations enabled by the internet of things. *Imp journal*, 9(1), 85–106. <https://www.emerald.com/insight/content/doi/10.1108/IMP-01-2015-0002/full/html>
- [14] Mudge, R. (2004). Using technology to manage and operate 21st century transportation systems (No. NCHRP Project 20-24, Task 33).
- [15] Lalit Abhilashi, B. K. Sarkar, Vandana Singh, S. K. P. (In Press). *New transportation engineering technology*. GEH Press.
- [16] Bathla, G., Bhadane, K., Singh, R. K., Kumar, R., Aluvalu, R., Krishnamurthi, R., & Basheer, S. (2022). Autonomous vehicles and intelligent automation: applications, challenges, and opportunities. *Mobile information systems*, 2022(1), 1–36. <https://onlinelibrary.wiley.com/doi/abs/10.1155/2022/7632892>
- [17] Khayyam, H., Javadi, B., Jalili, M., & Jazar, R. N. (2020). Artificial intelligence and internet of things for autonomous vehicles. *Nonlinear approaches in engineering applications: automotive applications of engineering problems*, 39–68.
- [18] Mahmood, Z. (2020). Connected vehicles in the IoV: concepts, technologies and architectures. In *Connected vehicles in the internet of things: concepts, technologies and frameworks for the iov* (pp. 3–18). Cham: Springer International Publishing. DOI: 10.1007/978-3-030-36167-9\_1
- [19] Coppola, R., & Morisio, M. (2016). Connected Car: technologies, issues, future trends. *ACM comput. surv.*, 49(3). DOI:10.1145/2971482
- [20] Blasch, E., Pham, T., Chong, C.-Y., Koch, W., Leung, H., Braines, D., & Abdelzaher, T. (2021). Machine learning/artificial intelligence for sensor data fusion—opportunities and challenges. *IEEE aerospace and electronic systems magazine*, 36(7), 80–93. <https://ieeexplore.ieee.org/abstract/document/9475913/>
- [21] Kumar, B., Milind, S., & Srivastava, M. (2024). Advancement of advanced driver assistance system in automobiles through iot implementation and integration. *2024 international conference on advances in computing, communication and applied informatics (ACCAI)* (pp. 1–9). IEEE. <https://ieeexplore.ieee.org/abstract/document/10602264/>
- [22] Campisi, T., Severino, A., Al-Rashid, M. A., & Pau, G. (2021). The Development of the smart cities in the connected and autonomous vehicles (CAVs) era: from mobility patterns to scaling in cities. *Infrastructures*, 6(7). DOI:10.3390/infrastructures6070100
- [23] Strayer, D. L., Cooper, J. M., McCarty, M. M., Getty, D. J., Wheatley, C. L., Motzkus, C. J., & Horrey, W. J. (2019). Visual and cognitive demands of carplay, android auto, and five native infotainment systems. *Human factors*, 61(8), 1371–1386.
- [24] Shin, Y., Kim, S., Jo, W., & Shon, T. (2022). Digital forensic case studies for in-vehicle infotainment systems using android auto and apple carplay. *Sensors*, 22(19), 7196.
- [25] Every, M., Layton, L., & Marin, J. M. (2019). A software-centric solution to automotive audio for general purpose cpus. *Audio engineering society conference: 2019 aes international conference on automotive audio*. Audio Engineering Society. <https://www.aes.org/e-lib/online/browse.cfm?elib=20536>
- [26] Cerruela García, G., Luque Ruiz, I., & Gómez-Nieto, M. Á. (2016). State of the art, trends and future of bluetooth low energy, near field communication and visible light communication in the development of smart cities. *Sensors*, 16(11), 1968.

- [27] Gupta, V., & Rohil, M. K. (2012). Enhancing wi-fi with IEEE 802.11 u for Mobile data offloading. *International journal of mobile network communications and telematics*, 2(4), 19–29.
- [28] Webb, J. J. C. Q. (2010). *Driving connectivity: the future of the US telematics industry and its impact to toyota motors (doctoral dissertation, massachusetts institute of technology)*.  
<https://dspace.mit.edu/handle/1721.1/59275>
- [29] Mitra, P., Simonds, C., Chen, Y., & Strumolo, G. (2017). In-vehicle health and wellness: an insider story. *Internet of things and data analytics handbook*, 427–445.  
<https://onlinelibrary.wiley.com/doi/abs/10.1002/9781119173601.ch25>
- [30] Lee, M. H., Park, H. G., Lee, S. H., Yoon, K. S., & Lee, K. S. (2013). An adaptive cruise control system for autonomous vehicles. *International journal of precision engineering and manufacturing*, 14, 373–380.  
<https://link.springer.com/article/10.1007/s12541-013-0052-8>
- [31] Baharuddin, M. I., Khamis, N. K., Kassim, K. A. A., & Mansor, M. R. A. (2019). Autonomous emergency brake (AEB) for pedestrian for asean ncap safety rating consideration: a review. *Journal of the society of automotive engineers malaysia*, 3(1), 63–73.
- [32] Mishra, S., Bhattacharya, D., & Gupta, A. (2018). Congestion adaptive traffic light control and notification architecture using Google maps APIs. *Data*, 3(4). DOI:10.3390/data3040067
- [33] Ramírez-Moreno, M. A., Keshtkar, S., Padilla-Reyes, D. A., Ramos-López, E., García-Martínez, M., Hernández-Luna, M. C., & Lozoya-Santos, J. de J. (2021). Sensors for sustainable smart cities: a review. *Applied sciences*, 11(17). DOI:10.3390/app11178198
- [34] Anil, A., Shukla, V. K., & Naranje, V. (2021). Tracking vehicles through gps module and arduino uno. *2021 9th international conference on reliability, infocom technologies and optimization (trends and future directions)(ICRITO)* (pp. 1–6). IEEE. <https://ieeexplore.ieee.org/abstract/document/9596167/>
- [35] Gorobetz, M., Timofejevs, J., Potapovs, A., & Obusevs, A. (2024). IoT-enabled single-camera speed sensor for smart city tasks. *Electronics*, 13(12), 2357.
- [36] Bara, G. G., Bara, P. C., Castanõn, J., & Barbosa, M. T. (2019). Evaluating the usability of a head-up display while driving a vehicle. *Advances in usability, user experience and assistive technology: proceedings of the ahfe 2018 international conferences on usability & user experience and human factors and assistive technology, held on july 21–25, 2018, in loews sapphire falls resort at* (pp. 184–194). Springer.  
[https://link.springer.com/chapter/10.1007/978-3-319-94947-5\\_18](https://link.springer.com/chapter/10.1007/978-3-319-94947-5_18)
- [37] Appadurai, M., Raj, E. F. I., & Rani, E. F. I. (2025). Application of self-powered sensors and actuators in engineering and medical domains. In *Self-powered aiot systems* (pp. 27–62). Apple Academic Press.  
<https://www.taylorfrancis.com/chapters/edit/10.1201/9781032684000-2/application-self-powered-sensors-actuators-engineering-medical-domains-appadurai-fantin-irudaya-raj-francy-irudaya-rani>
- [38] Mohammadi, F., & Rashidzadeh, R. (2021). An overview of IoT-enabled monitoring and control systems for electric vehicles. *IEEE instrumentation & measurement magazine*, 24(3), 91–97.  
<https://ieeexplore.ieee.org/abstract/document/9436092/>
- [39] Rahman, M. A., Rahim, M. A., Rahman, M. M., Moustafa, N., Razzak, I., Ahmad, T., & Patwary, M. N. (2022). A secure and intelligent framework for vehicle health monitoring exploiting big-data analytics. *IEEE transactions on intelligent transportation systems*, 23(10), 19727–19742.  
<https://ieeexplore.ieee.org/abstract/document/9668996/>
- [40] Karim, M., Rahman, M. A., Tan, S. W., Atiquzzaman, M., Pillai, P., & Alenezi, A. H. (In Press). Intra-vehicular Communication Protocol for IoT Enabled Vehicle Health Monitoring System: challenges, issues and Solutions. *IEEE ACCESS*. <https://ieeexplore.ieee.org/abstract/document/10587237/>
- [41] Joshi, S., & Rambola, R. K. (2021). IoT-enabled vehicle assistance system of highway resourcing for smart healthcare and sustainability. In *Emerging technologies for healthcare: internet of things and deep learning models* (pp. 337–358). Wiley Online Library. <https://doi.org/10.1002/9781119792345.ch14>
- [42] Farahpoor, M., Esparza, O., & Soriano, M. (2023). Comprehensive IoT-driven fleet management system for industrial vehicles. *IEEE ACCESS*.
- [43] Ghaffarpassand, O., Burke, M., Osei, L. K., Ursell, H., Chapman, S., & Pope, F. D. (2022). Vehicle telematics for safer, cleaner and more sustainable urban transport: a review. *Sustainability*, 14(24). DOI:10.3390/su142416386



- [44] Mishra, G., & Hegde, R. (2012). In-vehicle telematics-advanced technology contribution to intelligent automotives. *Journal of information systems and communication*, 3(1), 187. <https://search.proquest.com/openview/474337dd66b2d154cc493e35119e1935/1.pdf?pq-origsite=gscholar&cbl=616602>
- [45] Shah, K., Sheth, C., & Doshi, N. (2022). A survey on IoT-based smart cars, their functionalities and challenges. *Procedia computer science*, 210, 295–300. <https://www.sciencedirect.com/science/article/pii/S1877050922016106>
- [46] Muzahid, A. J. M., Kamarulzaman, S. F., Rahman, M. A., Murad, S. A., Kamal, M. A. S., & Alenezi, A. H. (2023). Multiple vehicle cooperation and collision avoidance in automated vehicles: survey and an AI-enabled conceptual framework. *Scientific reports*, 13(1), 603. <https://www.nature.com/articles/s41598-022-27026-9>
- [47] Chipengo, U. (2018). Full physics simulation study of guardrail radar-returns for 77 GHz automotive radar systems. *IEEE ACCESS*, 6, 70053–70060. <https://ieeexplore.ieee.org/abstract/document/8533336/>
- [48] Menon, V. G., Jacob, S., Joseph, S., Sehdev, P., Khosravi, M. R., & Al-Turjman, F. (2022). An IoT-enabled intelligent automobile system for smart cities. *Internet of things*, 18, 100213. DOI:<https://doi.org/10.1016/j.iot.2020.100213>
- [49] Kolasani, S. (2024). Connected cars and autonomous vehicles: personalizing owner/customer experiences and innovation using AI, IoT, Blockchain, and Big Data. *International numeric journal of machine learning and robots*, 8(8), 1–17.
- [50] Nicley, D. L. D., Lazaros, E. J., Truell, A. D., Zhao, J. J., & Davison, C. B. (2020). The connected car: a glimpse into the future of transportation. *Issues in information systems*, 21(2). [https://iacis.org/iis/2020/2\\_iis\\_2020\\_49-56.pdf](https://iacis.org/iis/2020/2_iis_2020_49-56.pdf)
- [51] Bale, A. S., Narayanaswamy, V., Shanthakumar, V. Y., Shyla, P. B., Balakrishna, S., Nagaraja, V. S., & Esarapu, E. (2022). Recent advancement in emergency vehicle communication system using IoT. In *IoT and big data analytics for smart cities* (pp. 121–158). Chapman and Hall/CRC. <https://www.taylorfrancis.com/chapters/edit/10.1201/9781003217404-7/>
- [52] Abdelwahab, S., Hamdaoui, B., Guizani, M., & Rayes, A. (2014). Enabling smart cloud services through remote sensing: An internet of everything enabler. *IEEE internet of things journal*, 1(3), 276–288. <https://ieeexplore.ieee.org/abstract/document/6817547/>
- [53] Ameen, H. A., Mahamad, A. K., Saon, S., Nor, D. M., & Ghazi, K. (2020). A review on vehicle to vehicle communication system applications. *Indonesian journal of electrical engineering and computer science*, 18(1), 188–198. <https://www.researchgate.net/profile/Hussein->
- [54] Zeadally, S., Guerrero, J., & Contreras, J. (2020). A tutorial survey on vehicle-to-vehicle communications. *Telecommunication systems*, 73(3), 469–489. DOI:10.1007/s11235-019-00639-8
- [55] Narayanan, P. S., & Joice, C. S. (2019). Vehicle-to-vehicle (V2V) communication using routing protocols: a review. *2019 international conference on smart structures and systems (ICSSS)* (pp. 1–10). IEEE.
- [56] Muslam, M. M. A. (2024). Enhancing Security in vehicle-to-vehicle communication: a comprehensive review of protocols and techniques. *Vehicles*, 6(1), 450–467. DOI:10.3390/vehicles6010020
- [57] Jiménez, F., Naranjo, J. E., Anaya, J. J., García, F., Ponz, A., & Armingol, J. M. (2016). Advanced driver assistance system for road environments to improve safety and efficiency. *Transportation research procedia*, 14, 2245–2254. <https://www.sciencedirect.com/science/article/pii/S2352146516302460>
- [58] Arena, F., & Pau, G. (2019). An overview of vehicular communications. *Future internet*, 11(2), 27. <https://www.mdpi.com/1999-5903/11/2/27>
- [59] Dey, K. C., Rayamajhi, A., Chowdhury, M., Bhavsar, P., & Martin, J. (2016). Vehicle-to-vehicle (V2V) and vehicle-to-infrastructure (V2I) communication in a heterogeneous wireless network—Performance evaluation. *Transportation research part c: emerging technologies*, 68, 168–184.
- [60] Kenney, J. B. (2011). Dedicated short-range communications (DSRC) standards in the United States. *Proceedings of the IEEE*, 99(7), 1162–1182.
- [61] Le, L., Festag, A., Baldessari, R., & Zhang, W. (2009). Vehicular wireless short-range communication for improving intersection safety. *IEEE communications magazine*, 47(11), 104–110.

- [62] Wu, X., Subramanian, S., Guha, R., White, R. G., Li, J., Lu, K. W., & Zhang, T. (2013). Vehicular communications using DSRC: Challenges, enhancements, and evolution. *IEEE journal on selected areas in communications*, 31(9), 399–408.
- [63] Michalski, R. A., & Vadekar, A. (2016). *Opportunities for enhancing the robustness and functionality of the dedicated short range communications (DSRC) infrastructure through the use of satellite dars to improve vehicle safety in the 21st century* [presentation]. 34th aiaa international communications satellite systems conference (p. 5713).
- [64] Abboud, K., Omar, H. A., & Zhuang, W. (2016). Interworking of DSRC and cellular network technologies for V2X communications: a survey. *IEEE transactions on vehicular technology*, 65(12), 9457–9470.
- [65] Zhang, T., Liu, S., Xiang, W., Xu, L., Qin, K., & Yan, X. (2019). A real-time channel prediction model based on neural networks for dedicated short-range communications. *Sensors*, 19(16), 3541.
- [66] Mahmood, Z. (2021). Connected vehicles: a vital component of smart transportation in an intelligent city. In *Developing and monitoring smart environments for intelligent cities* (pp. 198–215). IGI Global.
- [67] Hejazi, H., & Bokor, L. (2021). A survey on the use-cases and deployment efforts toward converged internet of things (IoT) and Vehicle-to-Everything (V2X) Environments. *Acta technica jaurinensis*, 15(2), 58–73. DOI:10.14513/actatechjaur.00627
- [68] Zadobrischi, E., Cosovanu, L.-M., & Dimian, M. (2020). Traffic flow density model and dynamic traffic congestion model simulation based on practice case with vehicle network and system traffic intelligent communication. *Symmetry*, 12(7). DOI:10.3390/sym12071172
- [69] Sanguesa, J. A., Barrachina, J., Fogue, M., Garrido, P., Martinez, F. J., Cano, J. C., & Manzoni, P. (2015). Sensing traffic density combining V2V and V2I wireless communications. *Sensors*, 15(12), 31794–31810.
- [70] Thakur, A., Malekian, R., & Bogatinoska, D. C. (2017). Internet of things based solutions for road safety and traffic management in intelligent transportation systems. *ICT innovations 2017: data-driven innovation. 9th international conference, ict innovations 2017, skopje, macedonia, september 18-23, 2017, proceedings 9* (pp. 47–56). Springer. [https://link.springer.com/chapter/10.1007/978-3-319-67597-8\\_5](https://link.springer.com/chapter/10.1007/978-3-319-67597-8_5)
- [71] Yang, K., Huang, Y., Qin, Y., Hu, C., & Tang, X. (2021). Potential and challenges to improve vehicle energy efficiency via V2X: Literature review. *International journal of vehicle performance*, 7(3–4), 244–265.
- [72] Priyanka, E. B., Shankar, M. G., Tharun, S., Ravisankar, S., Saravanan, S. N., Kumar, B. B., & Pugazhenthii, C. (2021). Real-time performance analysis of multiple parameters of automotive sensor's can data to predict vehicle driving efficiency. *International journal of computing and digital system*, 1337–1357.
- [73] Mukhtar, A., Xia, L., & Tang, T. B. (2015). Vehicle detection techniques for collision avoidance systems: a review. *IEEE transactions on intelligent transportation systems*, 16(5), 2318–2338. <https://ieeexplore.ieee.org/abstract/document/7066891/>
- [74] Shao, C., Tanaka, S., Nakayama, T., Hata, Y., & Muroyama, M. (2018). Electrical design and evaluation of asynchronous serial bus communication network of 48 sensor platform LSIs with single-ended I/O for integrated MEMS-LSI sensors. *Sensors*, 18(1), 231. <https://www.mdpi.com/1424-8220/18/1/231>
- [75] Canzian, L., Demiryurek, U., & van der Schaar, M. (2015). Collision detection by networked sensors. *IEEE transactions on signal and information processing over networks*, 2(1), 1–15. <https://ieeexplore.ieee.org/abstract/document/7342965/>
- [76] Nowakowski, C., Shladover, S. E., Cody, D., Bu, F., O'Connell, J., Spring, J., & Nelson, D. (2010). Cooperative adaptive cruise control: Testing drivers' choices of following distances. <https://escholarship.org/uc/item/58s2t0k3>
- [77] Silalahi, L. M., Alaydrus, M., Rochendi, A. D., & Muhtar, M. (2019). Design of tire pressure monitoring system using a pressure sensor base. *Sinergi*, 23(1), 70–78. <https://core.ac.uk/download/pdf/291842707.pdf>
- [78] Velupillai, S., & Guvenc, L. (2007). Tire pressure monitoring [applications of control]. *IEEE control systems magazine*, 27(6), 22–25.
- [79] Botaro, E. (2022). IoT-enabled environmental sensing for autonomous vehicle navigation and safety. *Journal of bioinformatics and artificial intelligence*, 2(2), 77–89. <https://biotechjournal.org/index.php/jbai/article/view/42>

- [80] Nasser, N., Ali, A. Y., Karim, L., & Al-Helali, A. (2024). Enhancing mobility for the visually impaired with ai and iot-enabled mobile applications. *ScienceOpen preprints*. <https://www.scienceopen.com/hosted-document?doi=10.14293/PR2199.000775.v2>
- [81] Khan, S. K., Shiwakoti, N., Stasinopoulos, P., & Chen, Y. (2020). Cyber-attacks in the next-generation cars, mitigation techniques, anticipated readiness and future directions. *Accident analysis & prevention*, 148, 105837. <https://www.sciencedirect.com/science/article/pii/S0001457520316572>
- [82] Karnouskos, S., & Kerschbaum, F. (2017). Privacy and integrity considerations in hyperconnected autonomous vehicles. *Proceedings of the IEEE*, 106(1), 160–170. <https://ieeexplore.ieee.org/abstract/document/8025389/>
- [83] Nižetić, S., Šolić, P., Gonzalez-De, D. L. I., & Patrono, L. (2020). Internet of things (IoT): opportunities, issues and challenges towards a smart and sustainable future. *Journal of cleaner production*, 274, 122877. <https://doi.org/10.1016/j.jclepro.2020.122877>
- [84] Gudapalli, K., Md, A. P., Yagateela, S. O., Gongati, A., Adnan, M. M., Anandhi, R. J., & Kumar, A. (2024). Driving sustainability: iot sensor integration for efficient car ac control. *E3S web of conferences* (Vol. 507, p. 1049). EDP Sciences. [https://www.e3s-conferences.org/articles/e3sconf/abs/2024/37/e3sconf\\_icftest2024\\_01049/e3sconf\\_icftest2024\\_01049.html](https://www.e3s-conferences.org/articles/e3sconf/abs/2024/37/e3sconf_icftest2024_01049/e3sconf_icftest2024_01049.html)
- [85] Alahi, M. E. E., Sukkuea, A., Tina, F. W., Nag, A., Kurdthongmee, W., Suwannarat, K., & Mukhopadhyay, S. C. (2023). Integration of IoT-enabled technologies and artificial intelligence (AI) for smart city scenario: recent advancements and future trends. *Sensors*, 23(11), 5206.
- [86] Cheruvu, S., Kumar, A., Smith, N., & Wheeler, D. M. (2020). *Demystifying internet of things security: successful iot device/edge and platform security deployment*. Springer Nature.
- [87] Tariq, N., Asim, M., Al-Obeidat, F., Zubair Farooqi, M., Baker, T., Hammoudeh, M., & Ghafir, I. (2019). The security of big data in fog-enabled iot applications including blockchain: a survey. *Sensors*, 19(8). DOI:10.3390/s19081788
- [88] Khattak, H. A., Farman, H., Jan, B., & Din, I. U. (2019). Toward integrating vehicular clouds with IoT for smart city services. *IEEE network*, 33(2), 65–71. <https://ieeexplore.ieee.org/abstract/document/8675174/>
- [89] Iqbal, J., Khan, M., Talha, M., Farman, H., Jan, B., Muhammad, A., & Khattak, H. A. (2018). A generic internet of things architecture for controlling electrical energy consumption in smart homes. *Sustainable cities and society*, 43, 443–450.
- [90] Shafique, K., Khawaja, B. A., Sabir, F., Qazi, S., & Mustaqim, M. (2020). Internet of things (IoT) for next-generation smart systems: a review of current challenges, future trends and prospects for emerging 5G-IoT scenarios. *IEEE access*, 8, 23022–23040. <https://ieeexplore.ieee.org/abstract/document/8972389/>